

Con. 5264-09.

SP-8525

(REVISED COURSE)

(3 Hours)

[Total Marks : 100

- N.B. (1) Question No. 1 is compulsory.
(2) Answer any four questions out of remaining six.
(3) Assume suitable data wherever required.
(4) Figures to the right indicate full marks.

1. Attempt any four from the following :— 20
- (a) Explain geometric modelling.
 - (b) What are the functions of graphics package ? Elaborate.
 - (c) What is the difference between Natural boundary condition and essential boundary condition ?
 - (d) State the general rules of mesh generation for Finite element formulations.
 - (e) What are sources of errors in F.E.M. solution ? Write in brief.
 - (f) What are the advantages and disadvantages of wire-frame models ?
2. (a) Write an algorithm to draw a line using DDA. 8
(b) Write transformation matrices for 2D and 3D graphics for— 12
- (i) Translation
 - (ii) Rotation
 - (iii) Scaling
 - (iv) Reflection.
3. (a) Analyse the truss completely i.e. for displacements, reactions, stresses and strains. 10

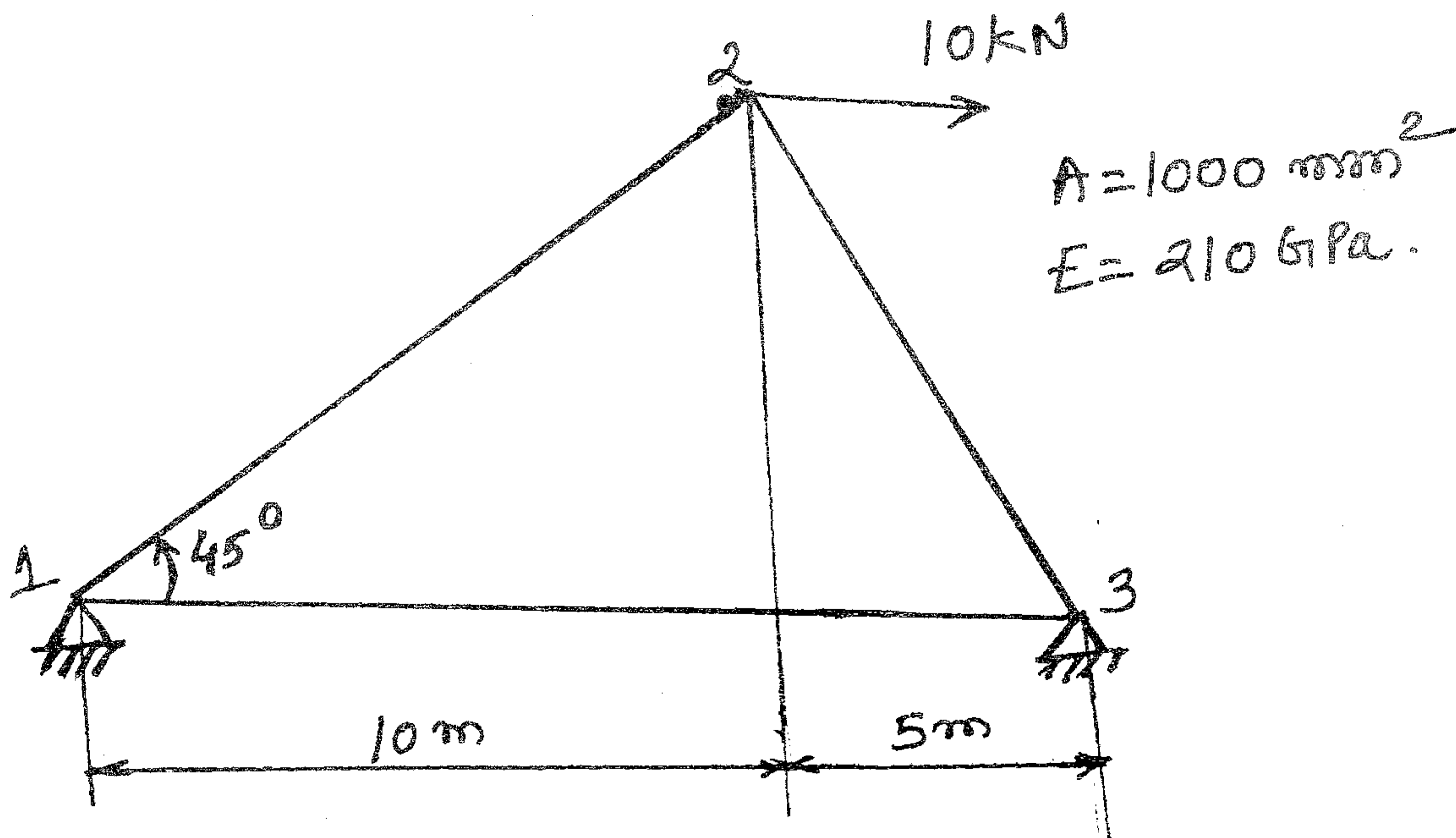

- (b) Explain linear and quadratic shape functions. 5
(c) Explain H and P methods in FEM. 5

[TURN OVER

Con. 5264-SP-8525-09.

2

4. (a) For the three-stepped bar shown in figure determine the displacements at node 2 and 3, stresses in the three sections and reactions at the ends. 10

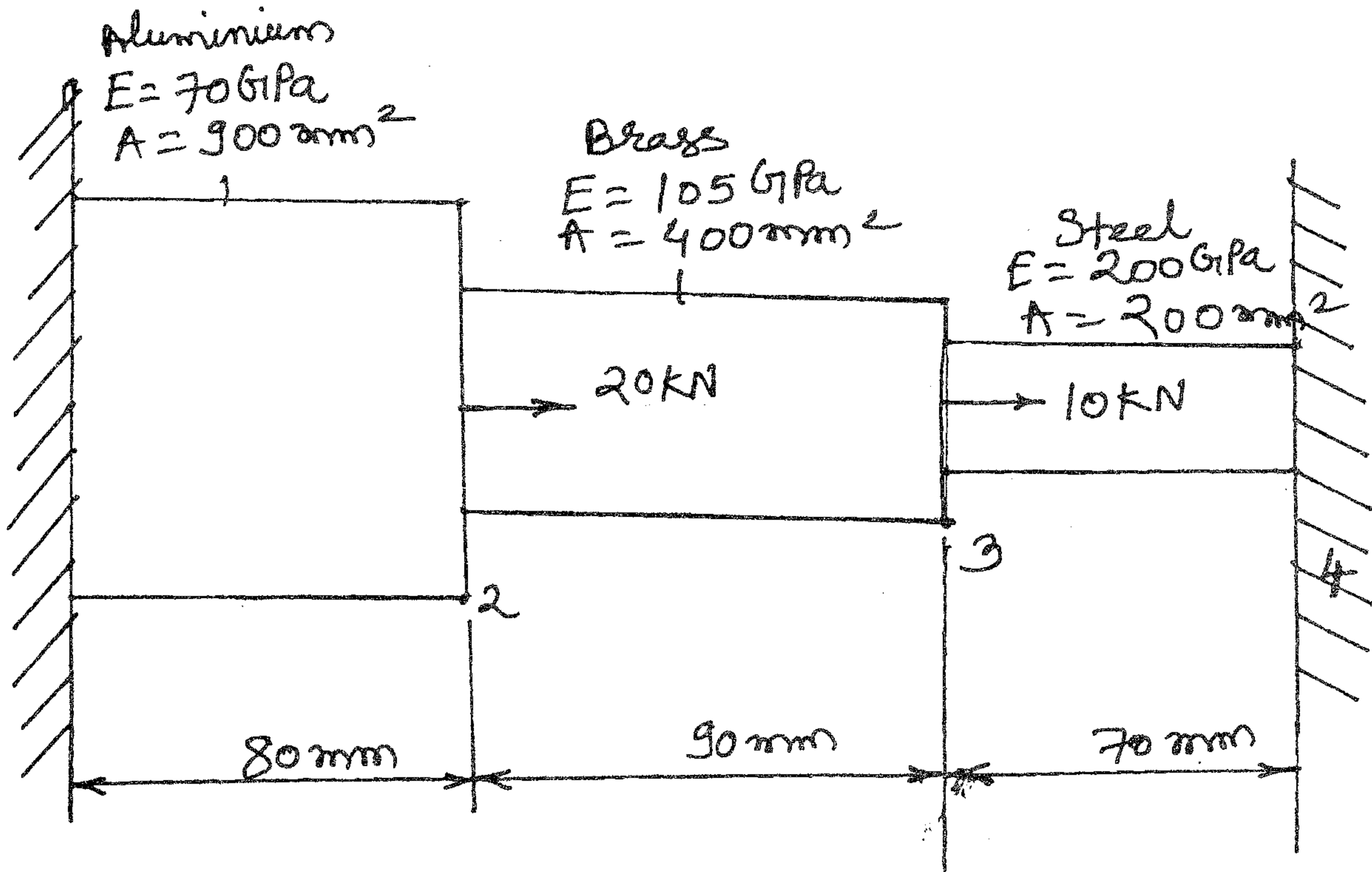

- (b) Explain choice of elements in FEM. 5
- (c) Explain post processing with reference to FEM software package. 5
5. (a) Reflect the diamond shaped polygon whose vertices are $A(-1, 0)$, $B(0, -2)$, $C(1, 0)$, $D(0, 2)$ about the vertical line $X = 2$. 5
- (b) Compare Bezier and B-spline curves. 5
- (c) Explain product life cycle with CAD/CAM overlay. 10
6. (a) What is product data exchange ? List data exchange formats available in the market. 8
- (b) Explain in detail with an example Initial graphic exchange specification (IGES) data exchange format. 12
7. Write short notes on :— 20
- (a) Application of F.E.M.
- (b) Merits and demerits of F.E.A.
- (c) Display technologies used for CAD
- (d) Input and Output devices.