

- N.B.:(1) Question No. 1 is compulsory.
 (2) Attempt any four questions from the remaining six questions.
 (3) Assume any suitable data wherever required but justify the same.
 (4) Figures to the right indicate full marks.
 (5) Answers to the questions should be grouped.

1. (a) Explain the term : (i) Kinematic chain (ii) Lower pair and Higher pair. 4
 (b) In a Whitworth Quick return motion as shown in Figure., OA and a crank 16
 rotating at 30 rpm in a clockwise direction. The dimensions of various links
 are OA = 150 mm, OC = 100 mm, CD = 125 mm, DR = 500 mm.
 Determine :
 (i) Velocity of sliding block R and angular velocity of lever CA.
 (ii) Acceleration of sliding block R and angular acceleration of lever CA.

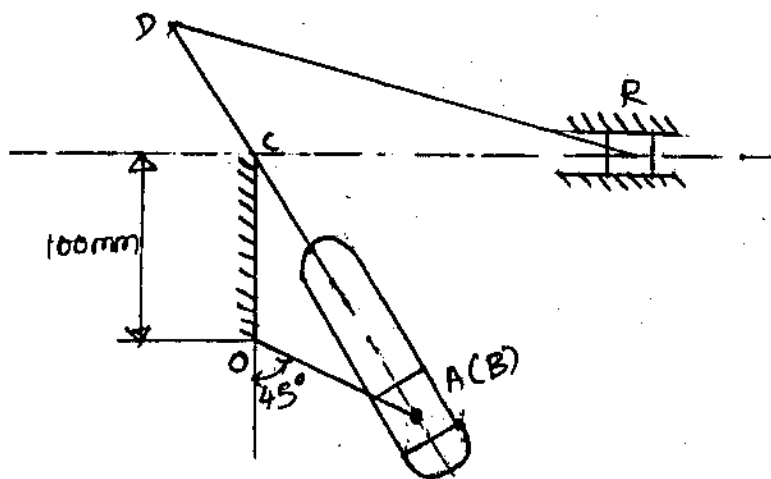

2. (a) Sketch and explain davis steering gear mechanism and show that it satisfies 6
 the condition of correct steering.
 (b) What do you mean by Coccoli's component at Acceleration ? Prove that this 6
 component of acceleration is equal to $2VW$.
 (c) State and explain different inversions of a single slider crank mechanism with 8
 one application each.
3. (a) What do you mean by degree of freedom of a mechanism ? Find out the 8
 degree of freedom of the following mechanisms :—

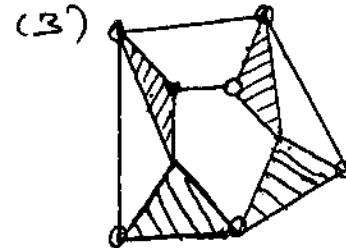
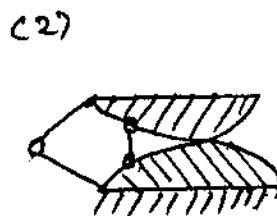
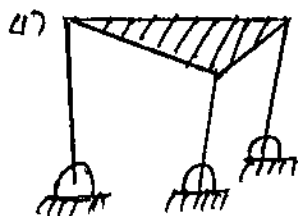

- (b) Give a neat sketch of the straight line motion "Hart mechanism". Prove that 8
 it produces an exact straight line motion.
 (c) Define— 4
 (i) Co-efficient of fluctuation of speed
 (ii) Co-efficient of fluctuation of energy.

4. (a) Two Involute gears of 20° pressure angle are in mesh. The Number of teeth on pinion is 20 and the gear ratio is 2. If the pitch expressed in module is 5 mm and the pitch line speed is 1.2 m/l, assuming addendum as standard and equal to one Module. 10
Find—
- The angle turned through by pinion when one pair of teeth is in mesh.
 - The maximum velocity of sliding.
- (b) Discuss the turning moment diagram of the multi cylinder engine. 4
(c) Analyse the gyroscopic effect due to pitching motion of Naval ships. 6

5. (a) A single plate clutch, effective on both sides is required to transmit 25 kW at 3000 rpm. Determine the outer and inner radii of frictional surface if the coefficient of friction is 0.255, the ratio of radii is 1.25 and the maximum pressure is not to exceed 0.1 N/mm^2 . Also determine the axial thrust to be provided by springs. Assume uniform wear theory. 10
(b) Show that in a band and block brake, the ratio of maximum tension to the minimum tension in the brake steps is given by :— 10

$$\frac{T_m}{T_o} = \left[\frac{1 + \mu + \tan\theta}{1 - \mu + \tan\theta} \right]^n$$

- T_m = Maximum tension
 T_o = Minimum tension
 μ = Co-efficient of friction
 θ = Semi angle of blocks
 n = Number of blocks.

6. (a) A, B, C and D are four masses carried by a rotating shaft at radii 100 mm, 125 mm, 200 mm and 150 mm respectively. The planes in which the masses revolve are spaced 600 mm apart and the masses B, C and D are 10 kg, 5 kg and 4 kg respectively. 10
Find the required mass A and the relative angular settings of the four masses so that the shaft shall be in complete balance.
- (b) The turbine rotor of a ship has a mass of 3500 kg. It has a radius of gyration of 0.45 m and a speed of 3000 rpm clockwise when looking from stem. Determine the gyroscopic couple and its effect on ship. 10
- When the ship is steering to the left on a curve of 100 m radius at a speed of 36 Km/hr.
 - When the ship is pitching in a simple harmonic motion, the bow falling with its maximum velocity. The period of pitching is 40 seconds and the total angular displacement between the two extreme positions of pitching is 12 degrees.
7. (a) Explain the term whirling speed of shaft. Prove that the whirling speed for a rotating shaft is the same as the frequency of natural transverse vibration. 10
(b) A cam is to be designed for a knife edge follower with the following data : 10
- Cam lift = 40 mm during 90° of cam rotation with simple harmonic motion.
 - Dwell for the next 30°
 - During the next 60° of cam rotation, the follower returns to its original position with simple harmonic motion.
 - Dwell during the remaining period. Draw the profile of cam when the line and stroke of follower is offset by 20 mm with the camshaft axis. The radius of base circle of the cam is 40 mm.