

Con. 3591-10.

(REVISED COURSE)

AN-3373

(3 Hours)

[Total Marks : 100]

- N. B. :** (1) Question No. 1 is compulsory.
 (2) Attempt any four questions out of the remaining six questions.
 (3) **Figures to the right indicate full marks.**
 (4) Assume suitable data if required.

1. Write short notes on the following :— (any four) 20
 (a) Centre of Pressure
 (b) Types of Rolling Mills
 (c) Gear Hobbing
 (d) Turning Fixture
 (e) Tool Dynamometer.
2. (a) Explain design principles common to jigs and fixtures. 10
 (b) What do you mean by tool life ? Explain effect of speed, feed, depth of cut, tool material and geometry on tool life. 10
3. (a) A circular cup shown in figure is manufactured using deep drawing process 14
 has a height of 48 mm and a diameter of 48 mm. The corner radius in 2 mm and work piece material is medium carbon steel and is 1mm thick. Determine the following parameters. (i) Blank Size (ii) Percent deduction (iii) No. of draws required (iv) Punch and die radius (v) Die clearance (vi) Drawing force (viii) Blank holding force.

$$(\sigma_y = \text{yield strength} = 427 \text{ N/mm}^2)$$

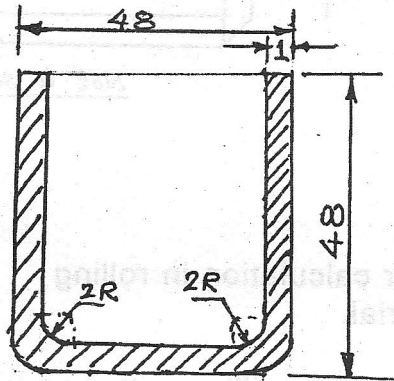

- (b) Explain with a neat sketch the orthogonal rake system (ORS) of describing a single point cutting tool geometry. 6
4. (a) The following data relate to orthogonal cutting of mild steel part : 10
 Cutting speed = 200 m/min ; Tool rake angle = 12° ;
 Width of cut = 1.8 mm; Uncut thickness = 0.2 mm.
 Average value of the coefficient of friction between the tool and the chip = 0.55 ; shear stress of work material = 390 N/mm^2 .
 Calculate : (i) Shear angle (ii) Cutting force (iii) Shear force
 (iv) Feed force OR Thrust force.
- (b) Clearly stating the assumption derive the relationship $2\phi + \beta - \gamma = \pi/2$ in Merchant's original theory. 10

[TURN OVER

Con. 3591-AN-3373-10.**2**

5. (a) Design and sketch around pull type broach for machining a cylindrical hole of diameter $40H_7$, length 50mm in a work piece of carbon steel. Assume rise per tooth in the range of 0.02 to 0.06mm. and broaching force required per mm. cutting edge length to be 12kgf. Broach is of HSS and permissible shear stress not to exceed 30kgf/mm^2 . **10**
- (b) Discuss the following :— **10**
- Types of bending dies.
 - Methods of reducing cutting force in cutting tool.
6. (a) Design a circular form tool graphically for the component given in figure. **10**
Rake and clearance angle are 12° and 8° respectively.

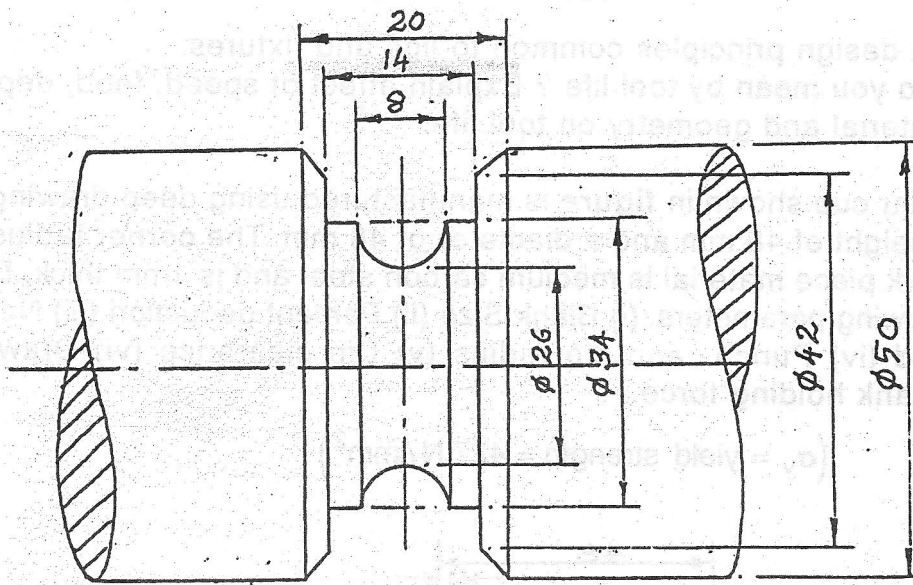
*Not to scale.*

- (b) Explain the following :— **10**
- Torque and power calculation in rolling
 - Cutting tool material.
7. (a) Draw the nomenclature of plain milling cutter and explain the procedure of designing a plain milling cutter. **10**
- (b) Explain the following :— **10**
- 'C'—clamp and captive 'C' clamp
 - Open type jig and channel type jig.