

- N.B. :** (1) Question No. 1 and 2 is **compulsory**.  
 (2) Out of remaining questions attempt any **three** questions.  
 (3) In **all five** questions to be attempted.  
 (4) **Figures** to the **right** indicate **full marks**.

1. Design a single stage R-C coupled CE amplifier for low frequency range 10 Hz to 20 KHz to give voltage gain  $|A_v| \geq 100$  with stability factor  $S \leq 10$  and output voltage  $V_o = 2.5$  V(rms). Use BC 147 B and specify  $V_{cc}$  required. Calculate  $A_v$ ,  $R_i$ ,  $R_o$  of designed circuit. 20
2. (a) Design an R-C coupled CS amplifier using FETBW-II to meet the following specifications  $|A_v| \geq 15$ ,  $I_{DSS} = 1.2$  mA,  $F_v \leq 20$  Hz,  $V_o = 2.5$  V,  $R_i \geq 1$  M ohm. 15  
 (b) A certain JFET has  $I_{DSS} = 15$  mA and pinch off voltage  $V_p = -5$  V. Calculate value of transconductance for  $V_{GS} = -2$  V. 5
3. (a) For full wave rectifier with center tapped transformer (15-0-15) rms, 50 Hz,  $R_1 = 20 \Omega$  15  
 (i) Find  $V_{dc}$ ,  $I_{dc}$  and ripple factor.  
 (ii) Repeat part 1 if 100 mH inductor is present in series with load.  
 (iii) Repeat part 1 if 20  $\mu$ F is considered and is shunted across the load.  
 (b) Draw UJT equivalent circuit and explain UJT characteristic curve. 5
4. (a) Find  $Z_o$ ,  $Z_i$ ,  $A_v$ ,  $A_i$  for the network given : 15

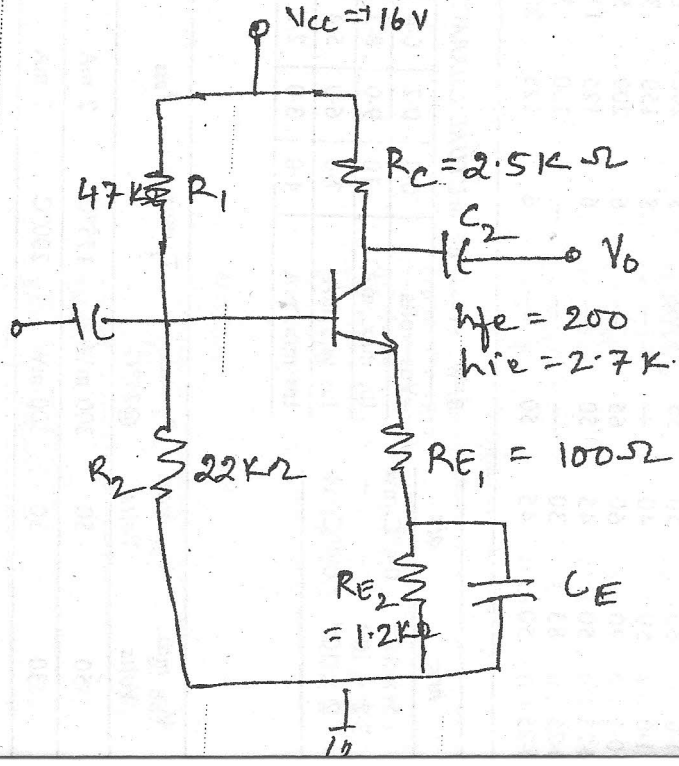

- (b) Explain the concept of zero Temperature drift in JFET. 5
5. (a) For a shunt zener regulators giving output voltage is 15V and load resistance 10  
 varying from 10 K $\Omega$  to 15 K $\Omega$ .  $V_{in}$  is varying between 20 to 24 V. Find :  
 (i) R series resistance (iii)  $S_V$   
 (ii)  $P_2(\text{max})$  (iv)  $R_O$ .
- Take  $R_2 = 8\Omega$   $I_{2(\text{min})} = 50 \mu\text{A}$
- (b) Explain the concept of Thermal runaway in BJT. 5  
 (c) Explain Latching current and holding current in SCR. 5
6. (a) Explain various methods of biasing JFET and MOSFET. 15  
 (b) Describe four ways an SCS can be turned off. 5
7. Write short notes on following :- 20  
 (a) Compare Diac and Triac (c) Critical inductance in filter  
 (b) Power MOSFET (d) UJT relaxation oscillators.

[TURN OVER

DBEC DATA SHEET

Transistor type	$P_{dmax}$	$I_{cmax}$	$V_{CE}^{(sat)}$	$V_{CBO}$	$V_{CEO}$	$V_{CER}$	$V_{CEX}$	$V_{BE0}$	$T_j$ max	D.C.	current	gain	Small	Signal	$h_{fe}$	$V_{BE}$	$\theta_{jc}$	Derat
	@ 25°C	@ 25°C	volts	volts	(Sus)	(Sus)	volts	volts										
	Watts	Amps	d.c.	d.c.	volts	d.c.	d.c.	d.c.	°C									W/°C
2N3055	115.5	15.0	1.1	100	60	70	90	7	200	20	50	70	15	50	120	1.8	1.5	0.7
ECN055	50.0	5.0	1.0	60	50	55	60	5	200	25	50	100	25	75	125	1.5	3.5	0.4
ECN149	30.0	4.0	1.0	50	40	—	—	8	150	30	50	110	33	60	115	1.2	4.0	0.3
ECN100	5.0	0.7	0.6	70	60	65	—	6	200	50	90	280	50	90	280	0.9	35	—
BC147A	0.25	0.1	0.25	50	45	50	—	6	125	115	180	220	125	220	260	0.9	—	—
2N525(PNP)	0.225	0.5	0.25	85	30	—	—	—	100	35	—	65	—	45	—	—	—	—
BC147B	0.25	0.1	0.25	50	45	50	—	6	125	200	290	450	240	330	500	0.9	—	—

Transistor type	$h_{ie}$	$h_{oe}$	$h_{re}$	$\theta_{ja}$
BC 147A	2.7 K $\Omega$	18 $\mu \Omega$	$1.5 \times 10^{-4}$	0.4°C/mw
2N 525 (PNP)	1.4 K $\Omega$	25 $\mu \Omega$	$3.2 \times 10^{-4}$	—
BC 147B	4.5 K $\Omega$	30 $\mu \Omega$	$2 \times 10^{-4}$	0.4°C/mw

BFW 11—JFET MUTUAL CHARACTERISTICS

-V <sub>GS</sub> volts	0.0	0.2	0.4	0.6	0.8	1.0	1.2	1.6	2.0	2.4	2.5	3.0	3.5	4.0
I <sub>DS</sub> max. mA	10	9.0	8.3	7.6	6.8	6.1	5.4	4.2	3.1	2.2	2.0	1.1	0.5	0.0
I <sub>DS</sub> typ. mA	7.0	6.0	5.4	4.6	4.0	3.3	2.7	1.7	0.8	0.2	0.0	0.0	0.0	0.0
I <sub>DS</sub> min. mA	4.0	3.0	2.2	1.6	1.0	0.5	0.0	0.0	0.0	0.0	0.0	0.0	0.0	0.0

N-Channel JFET

Type	$V_{DS}$ max.	$V_{DC}$ max.	$V_{GS}$ max.	$P_d$ max.	$T_j$ max.	$I_{DSS}$	$g_{mo}$	$-V_p$ Volts	$r_d$	Derate	$\theta_{ja}$
	Volts	Volts	Volts	@25°C						above 25°C	
2N3822	50	50	50	300 mW	175°C	2 mA	3000 $\mu\Omega$	6	50 K $\Omega$	2 mW/°C	0.59°C/mW
BFW 11 (typical)	30	30	30	300 mW	200°C	7 mA	5000 $\mu\Omega$	2.5	50 K $\Omega$	—	0.59° C/mW

UJT type	$P_d$ max.	$I_E$ max.	$I_P$	$V_{B2E}$	$V_{B2B1}$	$T_j$ max	$\eta$	$R_{BB}$ K $\Omega$	$I_P$	$I_V$	$I_{EO}$
	@25°C	@25°C	peak pulse current max.	Volts max.	Volts		min. max.	min. typ. Max.	max. $\mu A$	min. mA	$\mu A$
2N2646	300mW	50mA	2Amp.	30	35	125°C	0.56 0.75	4.7 7.0 9.1	5.0	4.0	-2.0